

4m Ultra Low Heavy Duty Widener

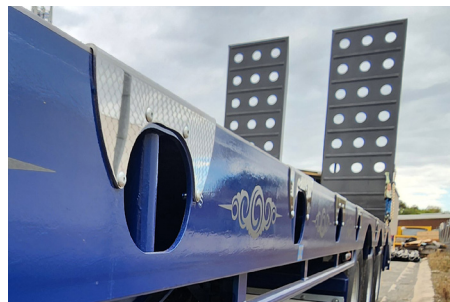

STANDARD FEATURES

Main Rails	Full length heavy duty main rail. 350 grade 8mm webs with a 20mm camber. 350 grade flanges – 16mm upper and 20mm lower flanges.	ATM	44,000kg.
Coaming Rails	125mm (5") PFC upper deck with 3 chain bars on each side. 200mm (8") PFC lower deck with 5 chain bars on each side.	GTM	Limits: 25t at 2.5m, 23t at 3m and 20t at 3.5m and 20t at 4.0m.
Flooring	5mm 700 grade floor including 33 deck tie downs.	Suspension	Fuwa K Hitch airbag tri-axle suspension with 19.5" 8 stud hubs.
Tyre Carrier	Tyre carrier suited for 19.5" spares only.	Hydraulics	Dual acting heavy-duty 3" cylinders fitted with anti-burst valves. 12v electric over hydraulic power pack.
Front Gate	1600mm high heavy-duty gate.	Landing Gear	2 speed heavy-duty Fuwa K Hitch landing legs.
Rear Ramps	Heavy-duty 2950mm x 900mm box tube construction with a 5mm steel plate surface and welded grip strips. Each ramp has a 10t point load rating and is secured with safety chains and dogs.	Wheels	Steel Painted rims with 265/70 19.5" tyres.
Upper Ramps	3 Piece flip over.	Lighting	Full multi-volt LED lighting with a LED beacon, Round 7-pin plug and a 175A Anderson plug.
Paint	Two colours of your choice. Sandblasted, primed and then finished with two coats of high quality 2 pack paint.	Toolbox	Powder coated toolbox with stainless steel door and 'T' bar locking handle with keys. Dimensions (1200mm x 350mm x 400mm)
Deck Height	975mm approx.	Water Tank	Polished 60 litre aluminium water tank.
		Overdose Signage	Custom made spring loaded flip-over signs.
		Flag Holders	Adjustable coaming rail flag holders at the front. Fixed flag holder mounts at the rear.



OPTIONAL FEATURES

- 3-way container pins with risers
- Road train provision
- Stainless steel coaming rail protectors
- Scrollwork and customised branding
- Additional deck tie-down plates
- Bi-fold ramps
- Extra wide ramps
- Additional toolboxes and timber cages
- Customised lighting
- Spare wheels
- Alloy wheels
- Wabco smart board, Opti-Link and Opti-Tyre
- Petrol or diesel hydraulic power packs
- 25,000lb electric winch
- Gate pockets

4m Ultra Low Heavy Duty Widener Trailer

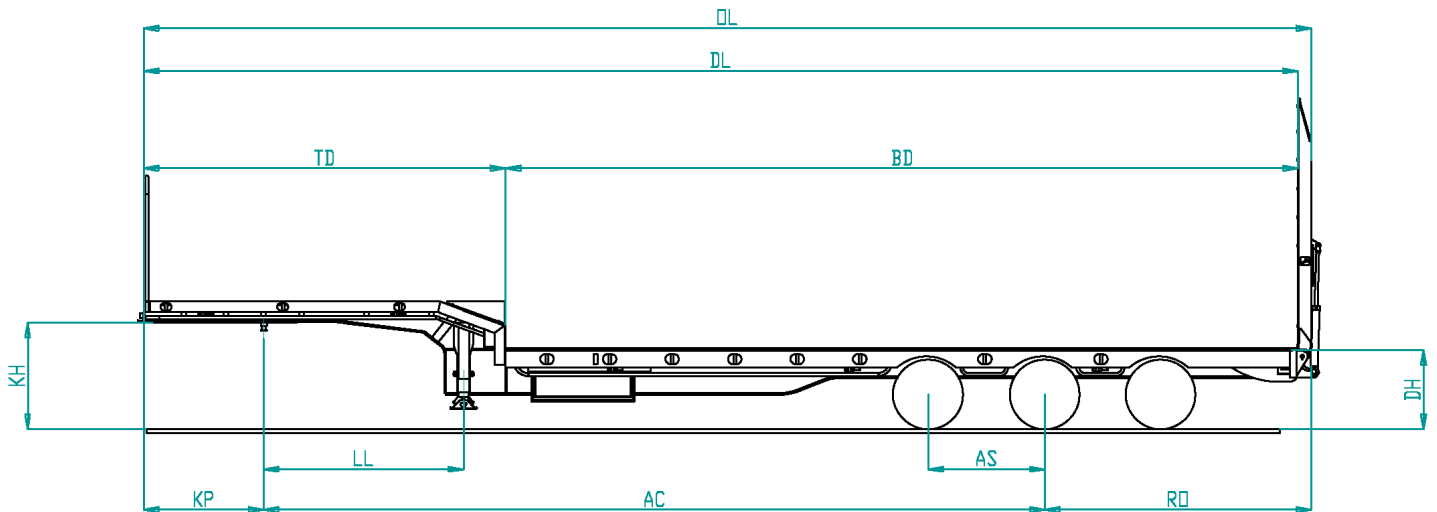
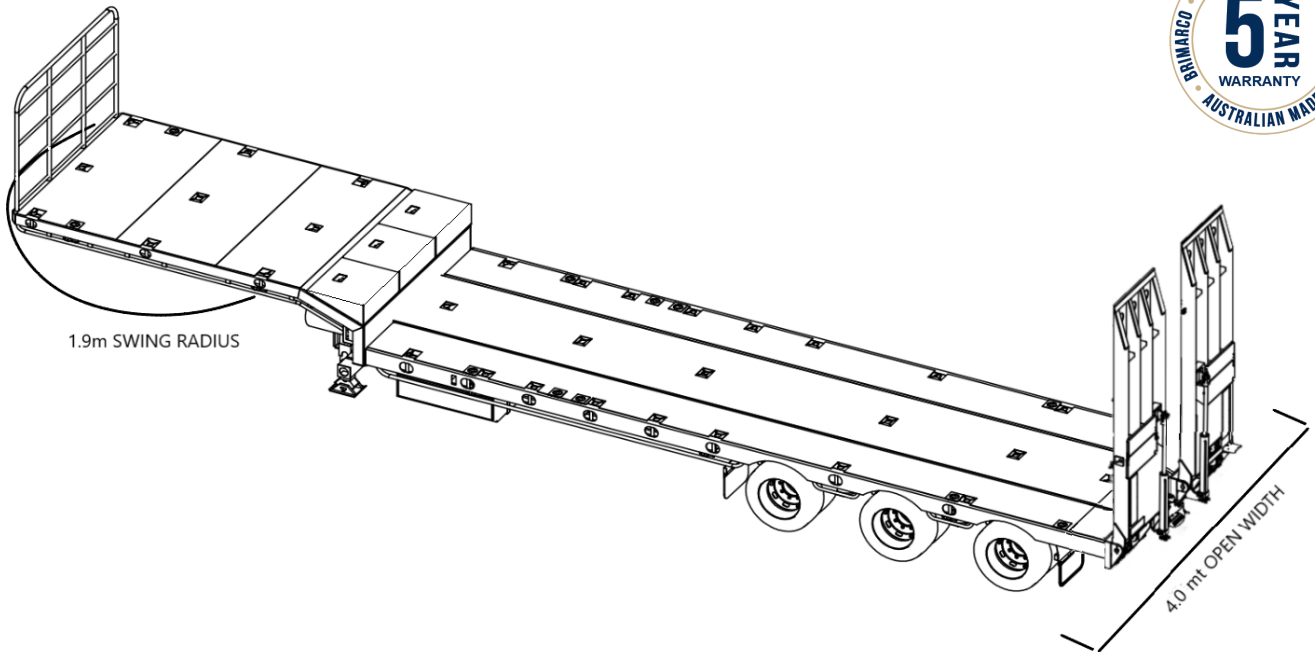

Standard Length Dimensions

Model	Length		Deck			Other					
	OL	DL	TD*	BD	DH	KH	KP	LL	AC	AS	RO
Road Train											
CR	13.65 (45ft)	13.3	4.3	9.3	0.98	1.27	1.4	2.4	8.95	1.4	3.27
Standard											
CA	14 (46ft)	13.7	4.3	9.7	0.98	1.27	1.4	2.4	9.3	1.4	3.25
Maximum											
CM	14.6 (48ft)	14.3	4.3	10.3	0.98	1.27	1.4	2.4	9.5	1.4	3.7

Legend

- OL Overall Length DL Deck Length TD Top Deck BD Bottom Deck DH Deck Height KH Kingpin Height
- KP Kingpin Centre LL Landing Leg AC Axle Centreline AS Axle Spacing RO Rear Overhang

Note: All dimensions are listed in metres (m)
 * Top deck length includes flip over ramp in position shown
 For custom lengths or other special requirements please contact Brimarco directly

